

INSTALLATION INSTRUCTIONS OF HAND CRANK HEIGHT ADJUSTABLE DESK

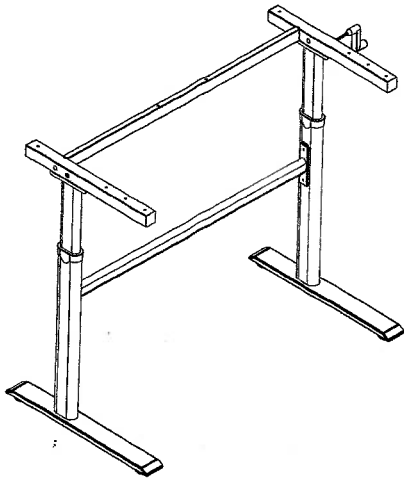

Technical Specification

Segments of leg	2
Max Load Capacity	40KG
Min. Height	700mm
Max. Height	1100mm

Screws pack

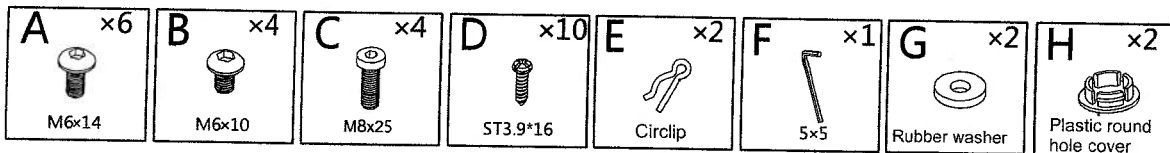

Component list

serial number	accessories	quantity	serial number	accessories	quantity	serial number	accessories	quantity
①	Bottom Feet	2	②	Left Leg	1	③	Right Leg	1
④	Center Rail	1	⑤	Rotating Bar	1	⑥	Left supporting bar	1
⑦	Right supporting bar	1	⑧	Leg fixing bar	1	⑨	Crank handle	1
⑩	Plastic square hole cover	4	⑪	Feet leveler	4	⑫	Table board	1

Installation Diagram

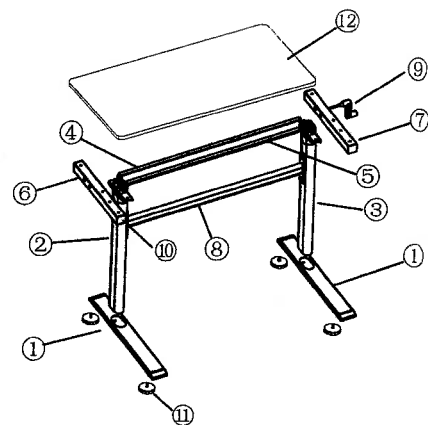

Installation Step 1

Install the center rail

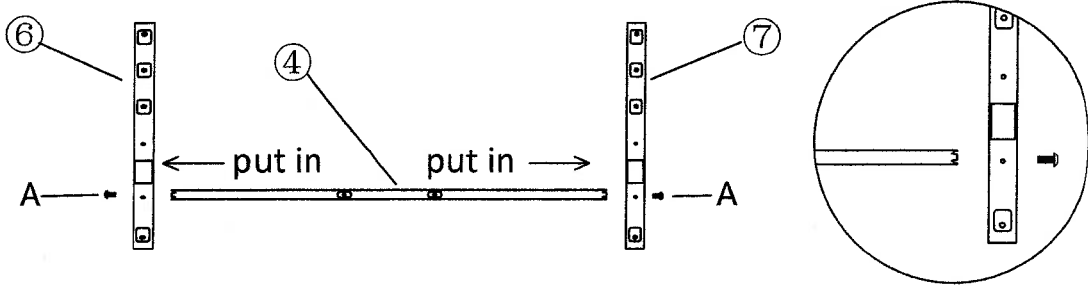
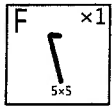

Connect left/right supporting bar with center rail by screw A, tighten by wrench 5x5 F.

Installation Step 2

Install the table board

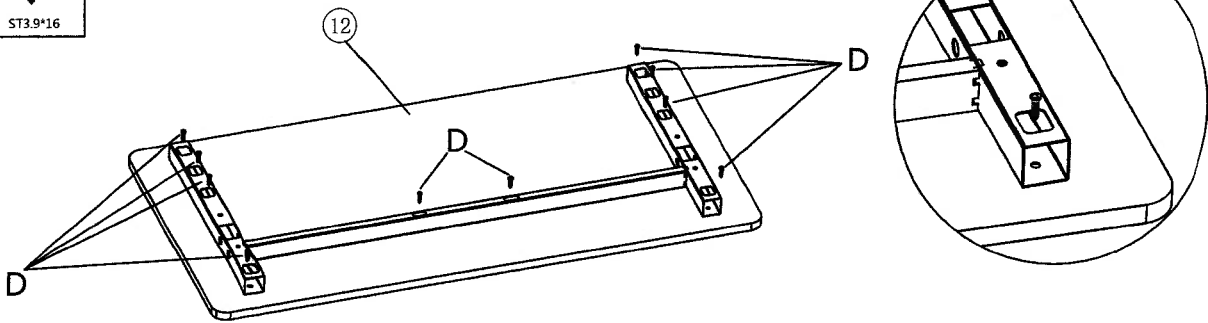

Connect frame with Table board by self-tapping screws D

Installation Step 3

Install hole covers

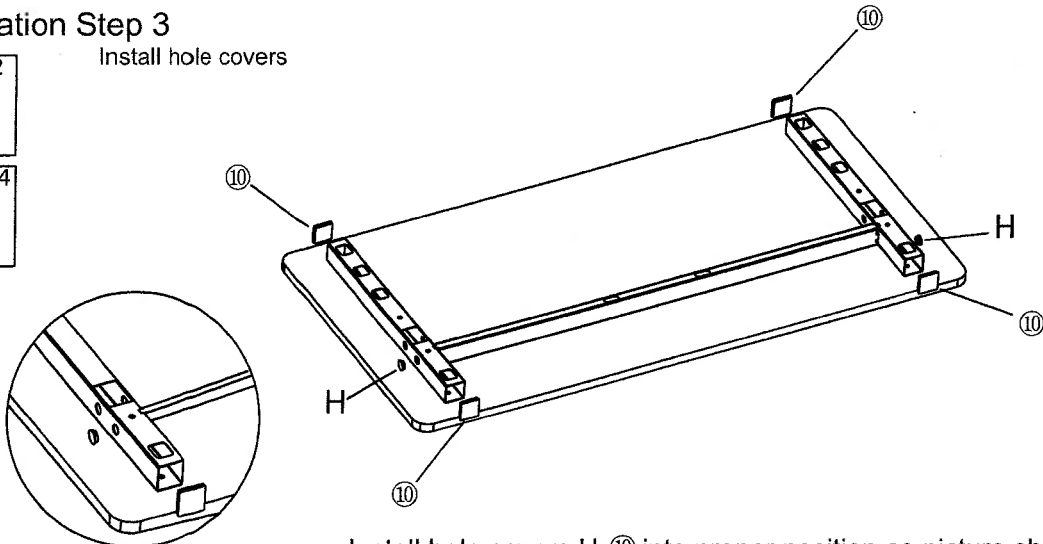

Install hole covers H, 10 into proper position as picture shows.

Installation Step 4

Install the legs

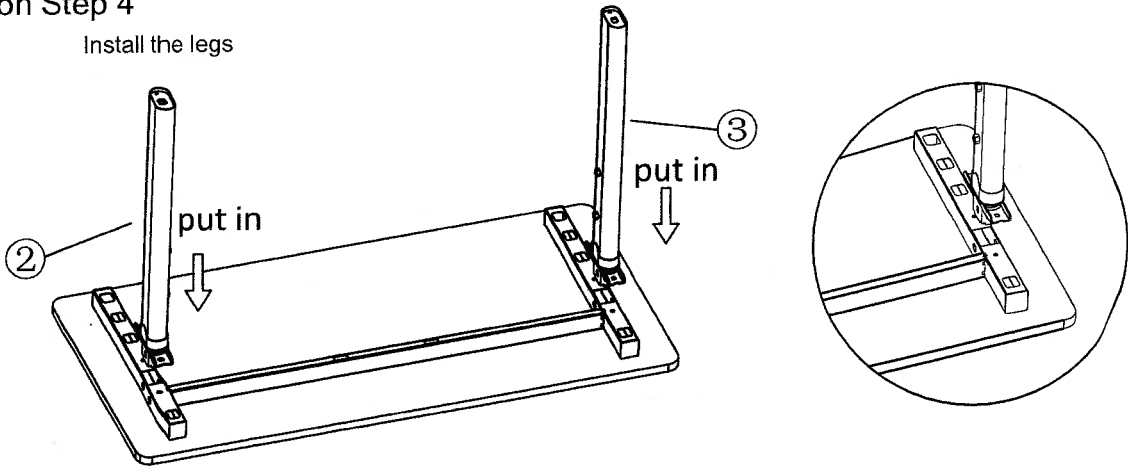

Connect left /right leg with the supporting bars,care for about the Screw holes position.

Installation Step 5

Tighten legs and install Leg fixing bar

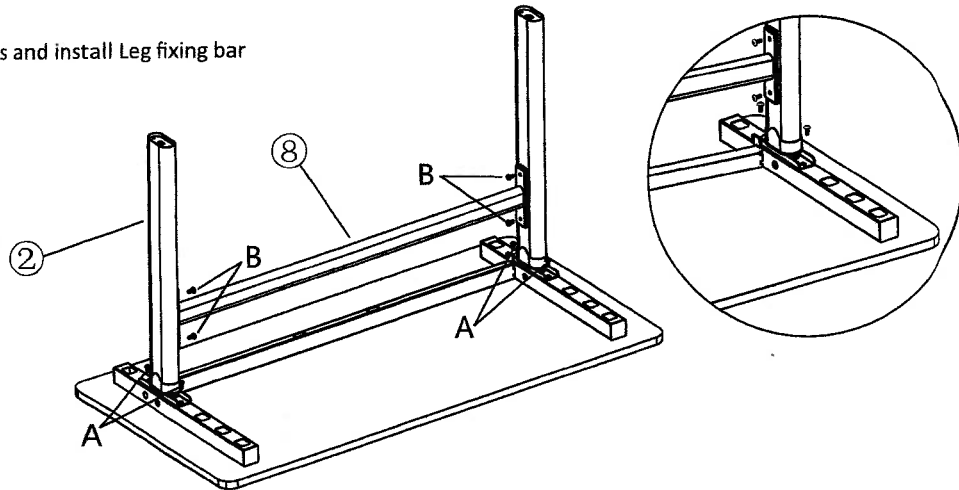
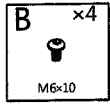
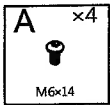
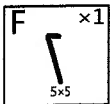

Tighten legs with supporting bar by screw A,install the fixing bar 8 and tighten it by screw B.

Installation Step 6

Rotating Bar

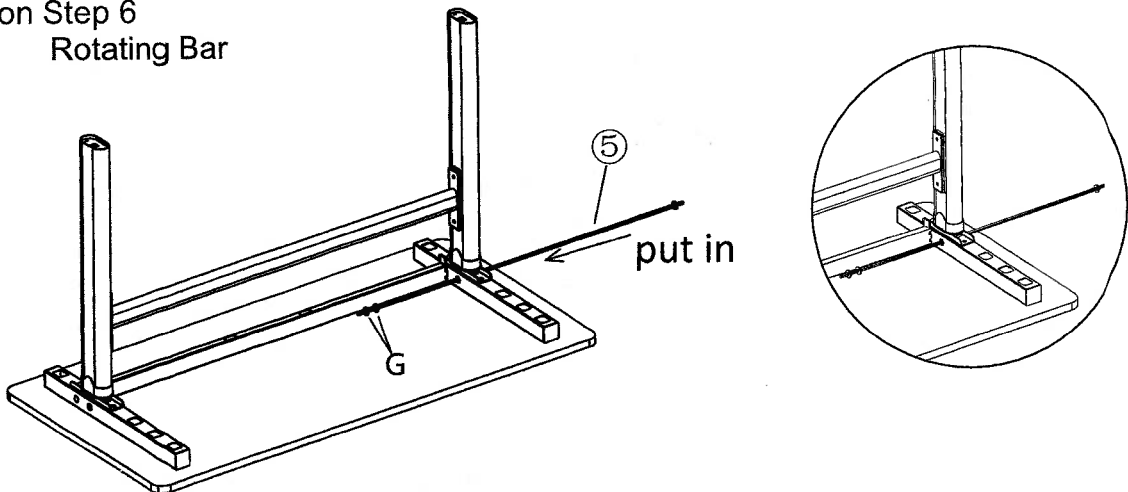

Cross the Rotatng Bar 5 from one Hexagon Hole and add two rubber washers G on it. Then cross another Hexagon Hole

Installation Step 7

Install the Circlips

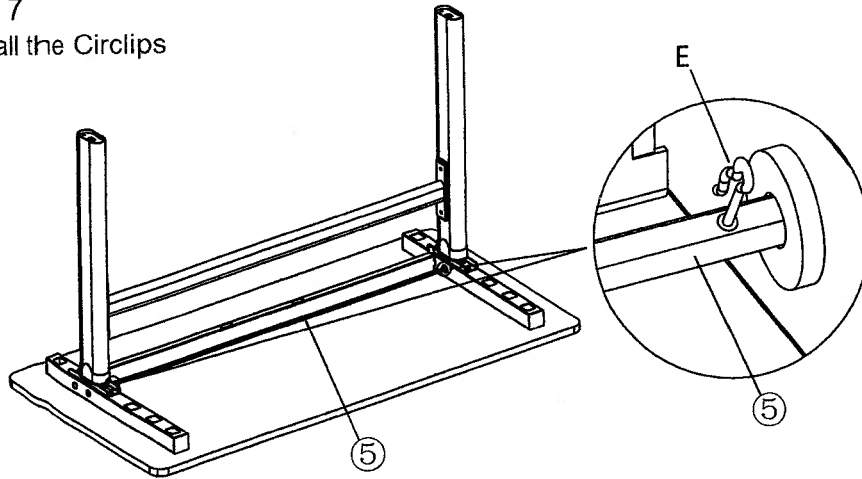
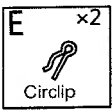

Install the two Circlips into the holes on the driving rod 5.

Installation Step 8

Install the feet , crank handel and screw in 4pcs feet levelers

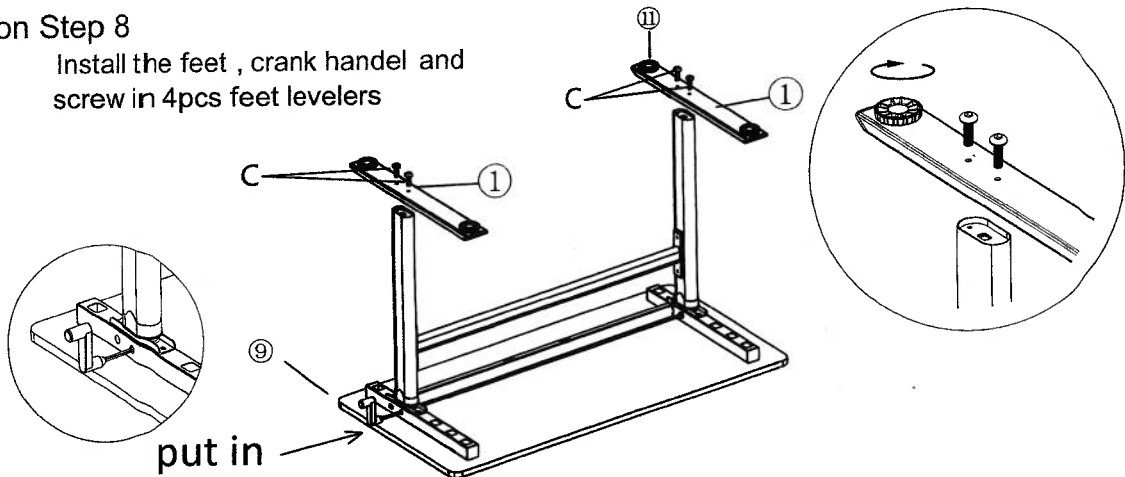
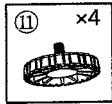
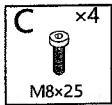
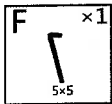

Connect feet 1 with leg by screws C, Tighten by wrench 5x5 F.
Install the crank handel 9 into the right hole position. Screw in 4 pcs feet levelers 11.

Waste Disposal

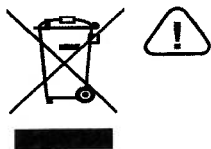

This sign indicates that the product should not be treated together with other domestic waste. In order to prevent potential harm to the environment and human beings caused by random treatment, It should be recycled to promote the sustainable reuse of material resources. When returning the equipment you use, please use the recycling and collection system or contact the retailer who purchased it. They are able to recycle while ensuring environmental safety.